

SERIE527

CONJUNTO DE MÓVEIS MODULARES (11PCS) - EXTENSÃO COM REF.16500 E REF.16493



INCLUI

x1	16493	ARMÁRIO COM 3 GAVETAS E SUPORTE PARA ROLO DE PAPEL (REF. 54327)
x2	16494	ARMÁRIO DE PAREDE (REF. 54327)
x1	16496	PLACA DE MDF 1360X500X38 MM (REF. 16627/16628/16500)
x4	16498	PANEL DE FERRAMENTAS 680X340X25 MM (REF. 54327)
x1	16500	ARMÁRIO COM 2 PORTAS (REF. 54327)
x3	16561	BARRA DE SUPORTE (REF.54327)

COMPONENTES

16500

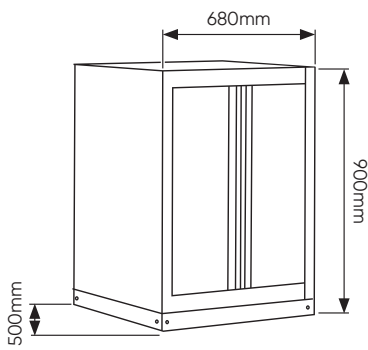

16493

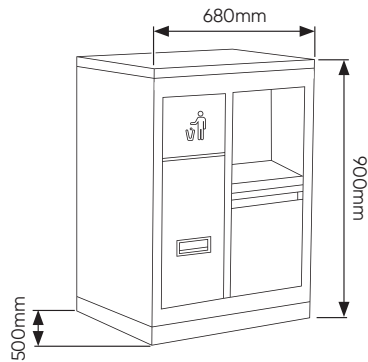

16494

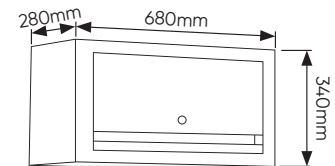

16498

338x25x680mm



16496

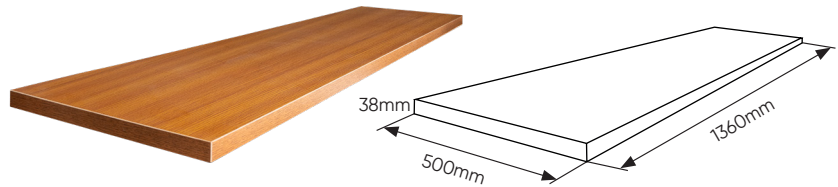

16561



COMPONENTES

SERIE527

